



NATURAL GAS ODORIZERS



Complete with
**GLASSLESS
MAGNETIC LEVEL
INDICATION**



SIMPLE & DEPENDABLE ODORIZATION

KingTool Natural Gas Odorizers

KingTool Company builds and stocks two different lines of natural gas odorizers. Both lines utilize the well-accepted absorption method. The “B” SERIES, or by-pass type odorizers, are used for flow rates up to eight million standard cubic feet per hour (based on an absorption rate of 0.5 lb. of odorant / mmscf gas); while the “W” SERIES, or small tap type odorizers, are recommended for flows less than five hundred standard cubic feet per hour. Both types are easy to operate and maintain, thereby making them excellent choices for your odorizing needs.

For “B” SERIES odorizers, a very small amount of the mainstream natural gas is by-passed through the odorizing unit. Then, the resulting odorant-laden gas is returned to the gas main to mix with the major portion of the gas flow. In its journey through the odorizer, the by-passed gas absorbs enough odorant to provide the desired odor intensity for the entire gas stream. An illustration on page 2 of this brochure shows an orifice, a partially-closed gate valve, or even a slightly-closed full-port ball valve, installed in the gas main, can provide the differential pressure required to operate the odorizer and maintain a direct relationship between the volume by-passed and the total volume flowing in the main. For the average installation, a maximum differential pressure of 30” to 80” of water column is sufficient to operate all “B” SERIES odorizers at their rated capacities. Smaller units or a unit operating well below its capacity will require much smaller differentials. Sometimes only a few inches are required to allow more precision valve adjustment. See the “Procedure for Initial Adjustment of the Precision Control Valve Used in King Gas Odorizers,” supplied with each “B” SERIES odorizer, for calculating a closer estimate of the differential pressure needed, versus the appropriate precision control valve setting, for your particular service. If there is any uncertainty, consult KingTool Company for recommendations. Note, precision valve control can be lost if the differential is too high or if the odorizer is too large for the application.

Once the proper differential pressure is established, the desired intensity of odor is then fine-tuned by adjustment of the precision control valve. Readjustments are seldom required since the ground temperature variation is small, and the odorizer normally compensates for most changes in flow rate.

KingTool Company’s by-pass odorizer is available in six (6) different sizes – Models 1-B, 2-B, 3-B, 4-B, 5-B, and 6-B. All six models are similar in design and operate in the same manner. These odorizers are highly efficient and economical. They have no moving parts and present almost no mechanical problems. The current design incorporates the use of a float -actuated level gauging system as in the past, except the level gauge glass has been replaced with KingTool’s Positive Action Indicator. This Positive Action Indicator is constructed without the use of tubular glass and the usual accompanying seals, which are the two primary sources of leaks around an odorizer, making this innovative level gauge a no-leak device. Plus, the Positive Action Indicator is completely compatible with all KingTool Company “B” SERIES odorizers and standard storage tanks purchased in the past, and can be retrofitted in just a few minutes.

The “B” SERIES odorizer is equipped with two 1/4” test/vent valves for determining the differential pressure, a thermometer well in which a test thermometer can be inserted to measure the temperature of the gas, and specific connections for filling and draining. In addition, 1/4” connections are provided so an above-ground storage tank can be utilized to manually fill the odorizer while remaining under pressure. “B” SERIES odorizers are usually buried, or are housed in constant temperature rooms, to ensure uniform odorization. Also, they require an odorant with a fairly narrow boiling range to prevent distillation effects in which high boiling point components accumulate in the odorizer while the light ends are being vaporized.

KingTool Company’s SMALL TAP ODORIZERS also require narrow boiling range odorants and are available in four Models --1-W, 3-W, 4-W, and 5-W. They are described on page 6.

Let KingTool Company’s Natural Gas Odorizers fill your gas odorizations needs – efficiently and economically. For additional information, prices, and/or deliveries contact:



Post Office Box 4639 • Longview, TX 75606
TEL: 903-759-4478 • FAX: 903-759-6781
sales@KingToolCompany.com
www.KingToolCompany.com

Typical installation of KingTool natural gas odorizers

ITEM	QUANTITY	SUGGESTED MATERIAL
1	1	Orifice Plate or Gate Valve
2	2	1"-Steel Angle Gate Valve
3	3	Valve Handle Extensions to Fit Conditions
4	2	1"-90° Elbows
5	2 Pr.	1"-Screwed Flanges or Unions
6	1	Valve Box with Cover
7	1	Concrete Block
8	1	King Tool Odorizer

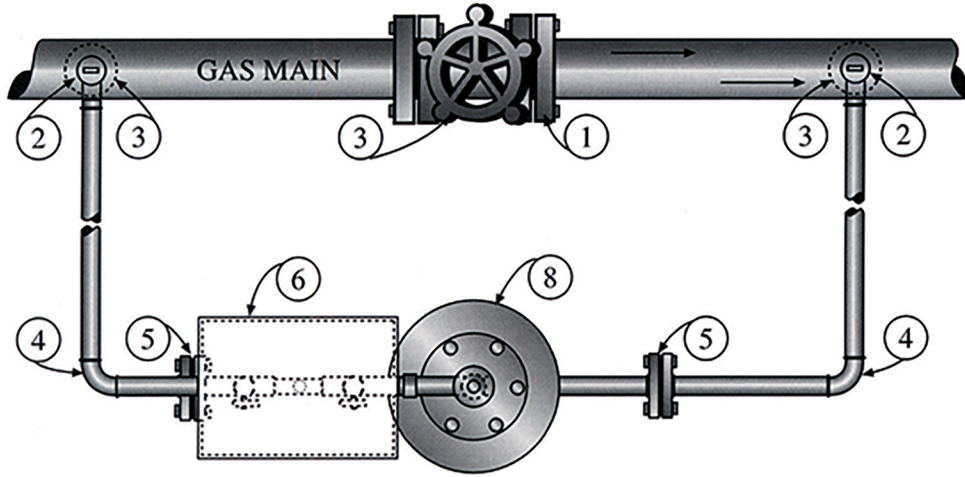

PLAN

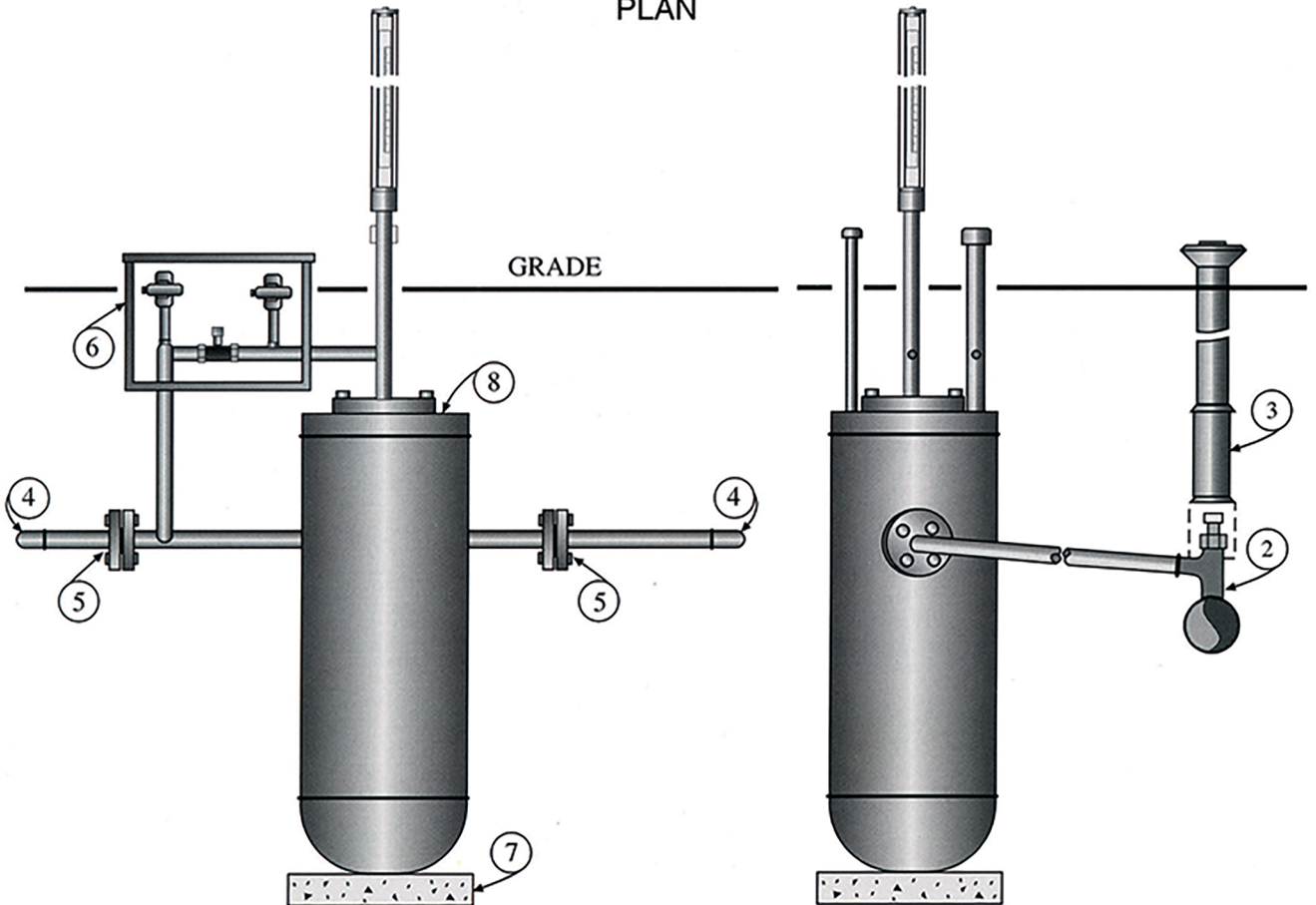

ELEVATION

ELEVATION
Outlet End

Odorizer Model

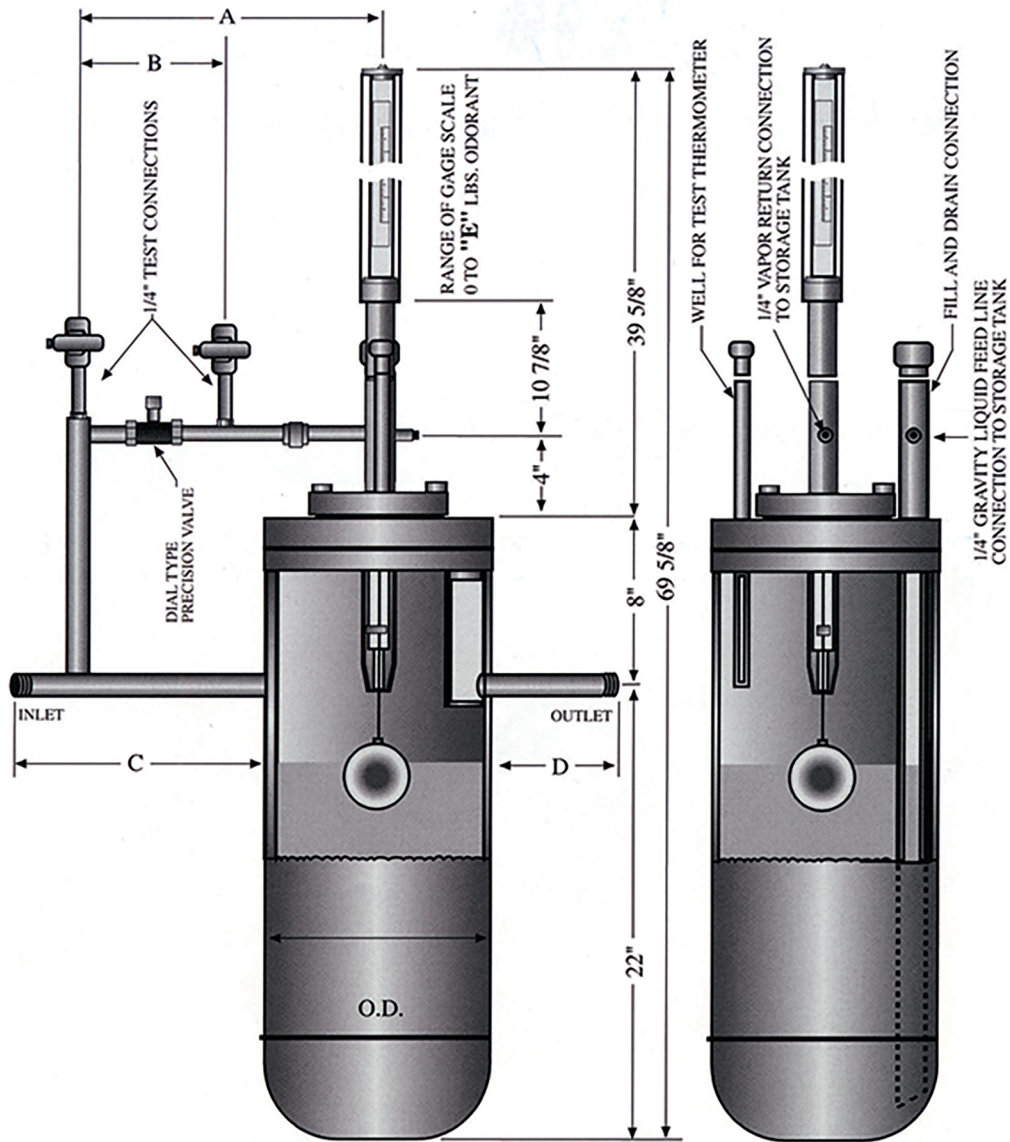

ODORIZER MODEL	DIMENSIONS					
	O.D.	A	B	C	D	E
1-B	6-5/8"	12"	6"	13"	4"	15
2-B	10-3/4"	13-7/8"	7-1/2"	12"	6"	40
3-B	16"	12-1/4"	6"	4-1/2"	3"	95
4-B	20"	12-1/4"	6"	4-1/2"	3"	140
5-B	24"	14"	7-1/2"	4-1/2"	3"	200
6-B	30"	17"	7-1/2"	4-1/2"	3"	370

Odorizer Selection Data

SPECIFICATIONS & PRICES	MODEL NUMBER					
	1-B	2-B	3-B	4-B	5-B	6-B
NPT Inlet & Outlet Size	1"	1"	1"	1"	1"	1"
Approx. Reservoir Capacity in Gallons	2.22	6.00	14.0	20.0	30.0	55.0
Gauge-Range in Lbs. Odorant**	15	40	95	140	200	370
Float Travel in Lbs. Odorant/In.**	0.85	2.38	5.5	8.7	12.8	19.6
Rated Capacity in Lbs. Odorant/Hr.**	0.15	0.50	0.75	1.00	1.50	4.00
Maximum Capacity in SCFH*	150,000	500,000	750,000	1,000,000	1,500,000	4,000,000
Approx. Shipping Wt. in Lbs.:						
300 PSIG Design	140	180	260	300	370	510
500 PSIG Design	140	195	340	440	475	720
720 PSIG Design	160	250	430	550	615	910
1000 PSIG Design	175	310	550	675	730	1200

*Based on 1 Lb. Spotleak 1009 Odorant / MMSCF Gas

**Based on Specifications of Spotleak 1009 Odorant at 6.76 Lbs / Gal.

NOTES:

1. All Models are available with design pressures of 300, 500, 720 or 1000 PSIG.
2. The maximum capacity shown above is based on the odorization rate shown. It is often desirable to purchase a larger odorizer to extend the time between refills. This is not recommended if usage is difficult to monitor at low flow rates. KingTool Company would then recommend using the properly sized odorizer, along with a storage tank, as shown on the following pages.
3. All odorizers can be operated at reduced flows. If the unit is to be constantly operated at less than 1/2 rate, contact KingTool for optimum valve sizing.
4. Lesser odorant concentration than that shown will allow proportionally greater flow.
5. Higher working pressure odorizer bodies than those shown can be furnished on request.
6. The 300 PSIG and 500 PSIG design odorizers are normally stocked in Longview, Texas.
7. Odorizer units can be furnished ASME code stamped on request at an additional charge.
8. The odorizers are sold complete with the Positive Action Indicator as shown on page 3.
9. Stainless steel precision control valves are available at an additional charge.

Mini Mist Remover

To help eliminate odorant masking due to hydrocarbon condensate and also water, KingTool offers our Mini Mist Remover. It has 1-NPT Inlet /Outlet connections so that it can be installed just upstream of any KingTool odorizer.

The unit as shown on the right is less than 36 inches in overall height. It has connections for a differential indicator, sight glass, and drains. The Mini Mist Remover is designed for 500 PSIG as standard. It is guaranteed to remove at least 99.9% by weight of all mist and associated solid particles one (1) micron or larger.

It has a replaceable cartridge which can be changed via the flanged top. Spare cartridges are available from KingTool.

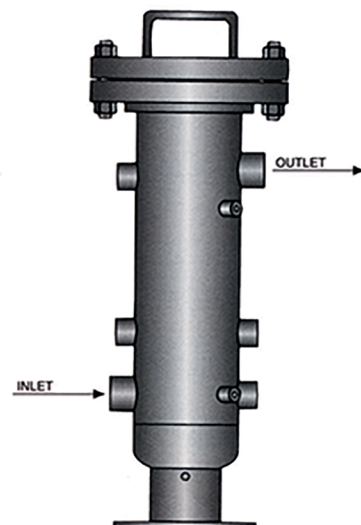

Odorant Storage Tanks

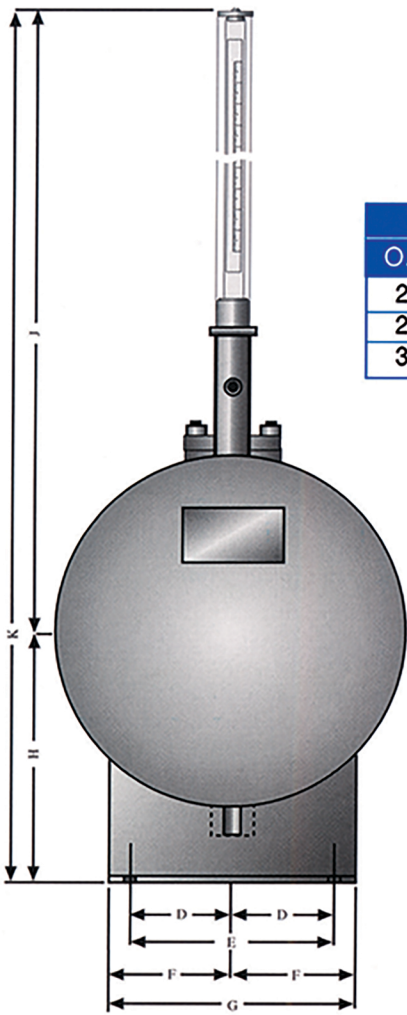

DIMENSIONAL DATA										
O.D.	A	B	C	D	E	F	G	H	J	K
20"	56"	28"	7"	5-1/2"	11"	7"	14"	14-1/4"	41-3/16"	55-7/16"
24"	58"	29"	8"	7"	14"	8-1/2"	17"	16-1/2"	43-3/16"	59-11/16"
30"	62"	31"	10"	9"	18"	10-1/2"	21"	20"	45-3/16"	66-3/16"

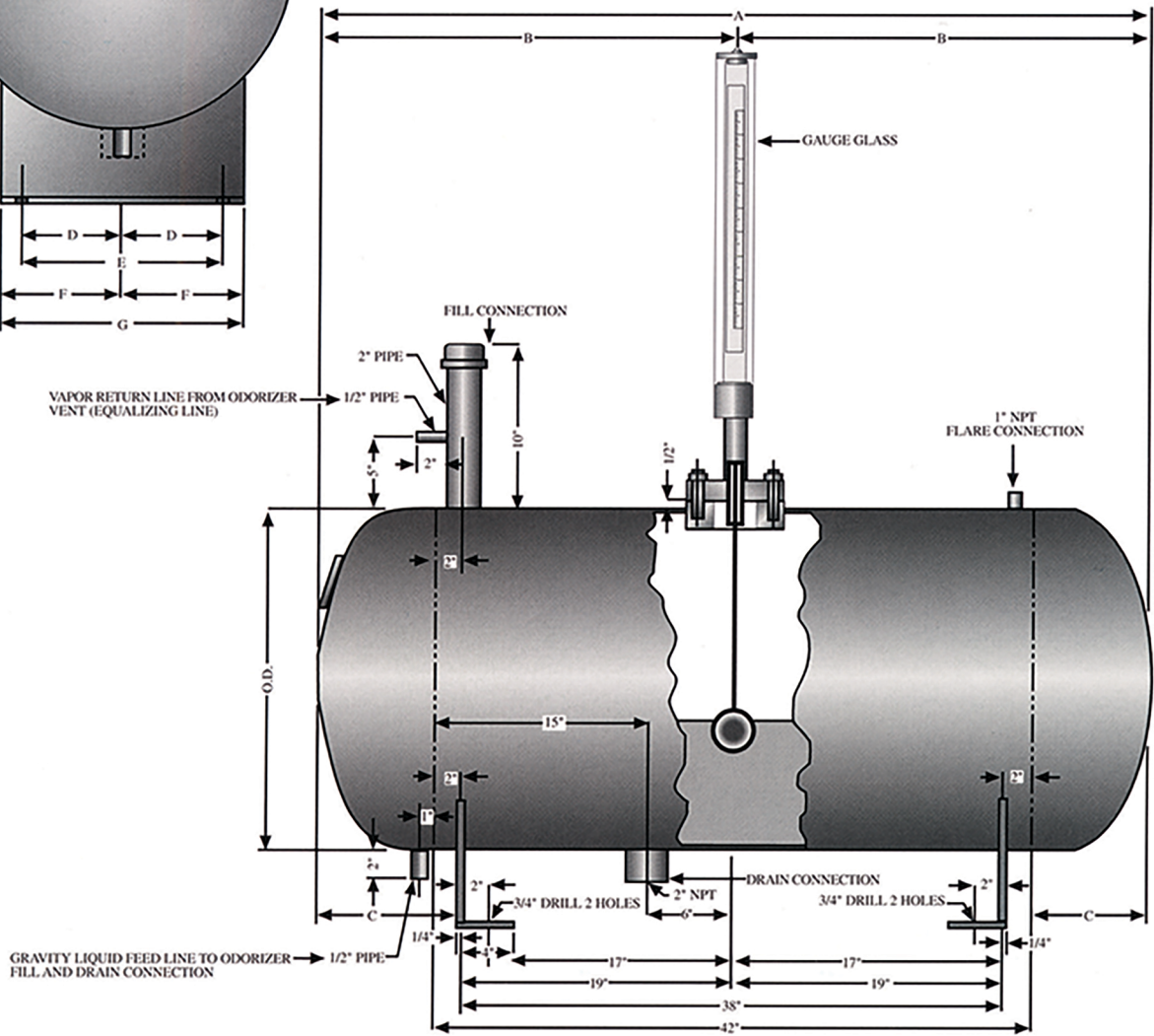

Odorant Storage Tanks

To complement the complete line of KING by-pass odorizers KingTool Company offers a series of odorant storage tanks for use in maintaining a supply of odorant at the installation site.

As shown on the previous page, these tanks can be used for above ground storage or if furnished without the supports -can be buried underground alongside the odorizer proper.

These tanks are installed using a liquid fill line, with valve, from the storage tank to the odorizer fill line and with a balance line from the odorizer Positive Action Indicator column to the top of the storage tank. This arrangement allows the odorizer to be gravity filled while under pressure. The odorant storage tanks are designed and constructed to meet the requirements of the ASME Code, and they can be stamped upon request at an additional charge.

Larger capacity storage tanks (i.e. 36", 42", 48" I.D.) are available upon request. Standard design pressures are 300 PSIG, 500 PSIG and 1000 PSIG.

STORAGE TANK DATA				
Outside Diameter In Inches	Capacity In Gallons	Vessel Weights in Lbs		
		300 PSIG Design	500 PSIG Design	1000 PSIG Design
20	60	350	430	645
24	100	470	555	765
30	150	735	820	1030

Small Tap Odorizers

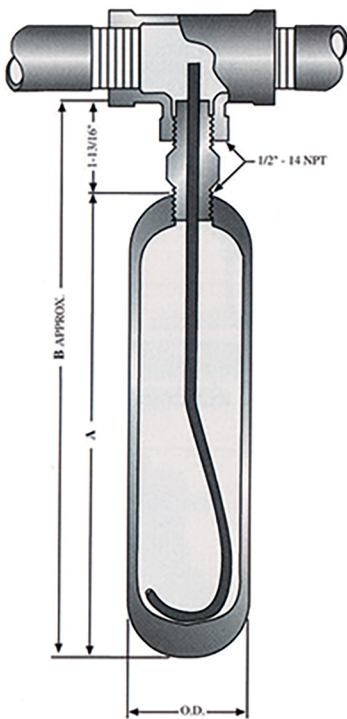

NON-ADJUSTABLE WICK

The 'W' Series is offered for very small flow applications. The "W" units are furnished for domestic farm taps, camps, trailers, instrumentation leak detection and other related needs.

The rating of each model is 500 SCFH except for the 4-W and the design pressure is 300 PSIG. Where some continuous flow is known to exist, the 3-W or 5-W is recommended over the 1-W because of its larger reservoir capacity.

The 4-W model, complete with Positive Action Indicator and fill connection, uses a special, larger wick assembly to allow onstream adjustments to gas odorant concentration. It has a higher rated capacity of 5000 SCFH. Higher design pressures are available upon request for model 4-W units.

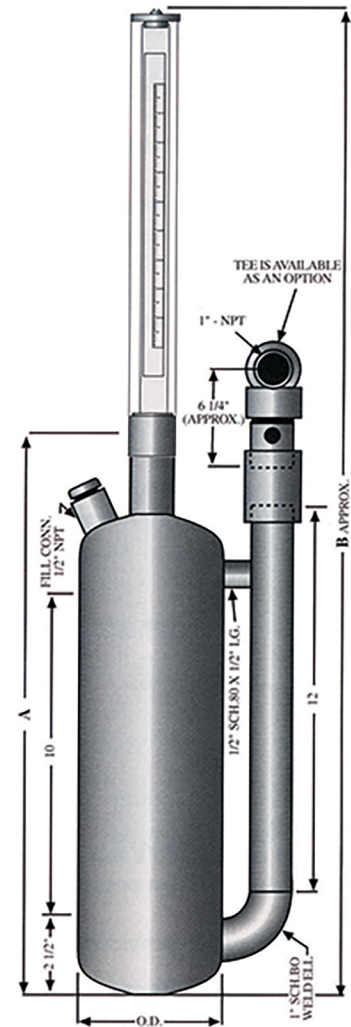

4-W ADJUSTABLE WICK

GENERAL INFORMATION

Size	A	B	OD.	Capacity	Weight
1-W	9-3/16"	11"	2-3/8"	One Pint	4 Lbs.
3-W	12"	14"	3-1/2"	One Quart	9 Lbs.
4-W	17-1/2"	30"	4-1/2"	Three Quart	25 Lbs.
5-W	14"	16"	4-1/2"	Three Quart	21 Lbs.

Positive Action Indicator

Now being supplied with KingTool Company "B" SERIES line of natural gas odorizers and odorant storage tanks is our Positive Action Indicator. This "glassless" level gauge is also interchangeable with gauge glasses currently in use on all of these same KingTool models for 300, 500, 720, and 1000 PSIG.

The Positive Action Indicator features a fully sealed, leak-proof assembly utilizing a stainless steel tube, a magnetic power capsule, and a brightly colored indicator ring for its level indication; all encased in a special see-through plastic. No more glass! No more leaking seals! Also, our scales have been upgraded to ten divisions per inch all black embossed, and a weather cover is being furnished to protect the indicator from the elements.

The Positive Action Indicator's robust construction and simplicity of operation is designed to provide many years of safe, trouble-free service.

Positive Action Indicator

- Fully sealed and leak-proof.
- Easy-to-read indicator scale.
- Easy to fit-no special tools required.
- Tested to one and a half times above design pressure.
- Weather cover provided.

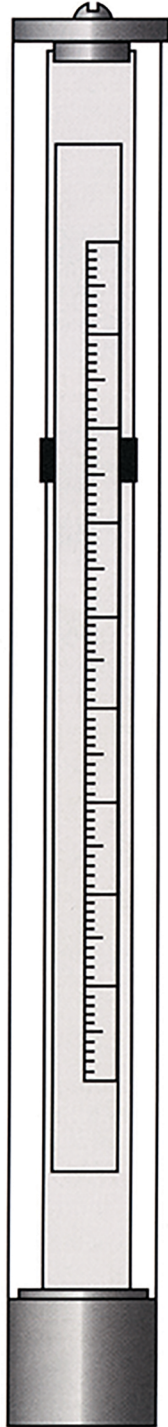

In addition to the Natural Gas Odorizers and Storage Tanks described in this publication, KingTool manufactures and supplies a complete line of gas filter/separation equipment, including:

**SELF CLEANING
REVERSE FLOW
MIST COALESCERS
& FILTER-SEPARATORS**



**NON-SELF-CLEANING
FILTER SEPARATOR**



**HORIZONTAL
& VERTICAL
SEPARATORS**



**OIL BATH GAS
SEPARATOR-
SCRUBBERS**



**HORIZONTAL &
VERTICAL UTILITY
GAS FILTERS &
FILTER SEPARATORS**



**LINE SEPARATORS
& FILTERS**



KingTool
COMPANY

Post Office Box 4639 • Longview, TX 75606
TEL: 903-759-4478 • FAX: 903-759-6781
sales@KingToolCompany.com
www.KingToolCompany.com